



EBARA

ISO 9002
KEMA
CERT. NR.
DUTCH COUNCIL FOR ACCREDITATION



FS8001A-6

END SUCTION VOLUTE PUMP

Model **FSA**

60Hz



CEBU CHAMPION HARDWARE, INC

AUTOMATION & CONTROL * WATER SYSTEM AND FIRE PROTECTION SYSTEM

#11 Pres. Quirino, Villa Aurora Subd., Kasambagan, Cebu City, Philippines

Tel. Nos.: (032) 231-7139 • 412-7580 • 238-9343 Telefax : (032) 234-4342

Website: www.cebuchampionhardware.com



END SUCTION VOLUTE PUMP

FEATURES

1. Easy maintenance BPO (Back Pull Out) feature allows all rotating element to be removed without disconnecting the suction and discharge pipework.
2. Top centerline discharge, foot support under casing for maximum resistance to misalignment and distortion from pipe loads.
3. Higher operating efficiency over a wider range of capacities, lowers operational cost.

APPLICATIONS

1. Water supply.
2. Hot and cold water circulation.
3. For cooling tower.
4. Fire-fighting application.
5. Irrigation.
6. Industrial use.
7. Drainage.

MODEL CODE

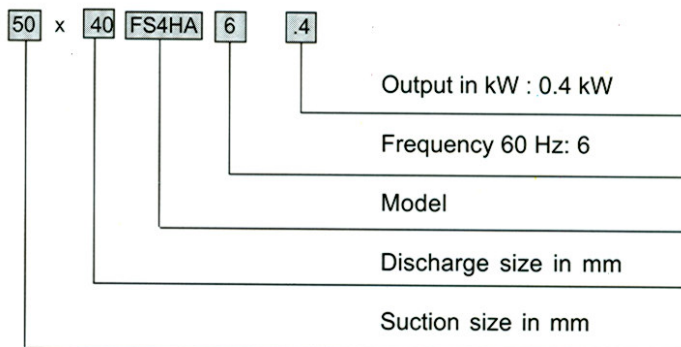

SPECIFICATION

Description		Standard	Option
Model		FSA	
No. of Pole		2 4	
Liquid Handled	Type of liquid	Clean Water	
	Temperature	0-100°C(32-212°F)	
Max. Positive Suction Pressure (kgf/cm ²) for Mechanical Seal		FSGA : 8.2 - (Shutoff pressure) FSHA, FSJA : 10.2 -(Shutoff pressure)	All except FSLA : 8.2 - (Shutoff pressure) FSLA : 10.2-(Shutoff pressure)
Max. Working Pressure		10.2 kgf/cm ² (10 bar)	
Available Suction Lift		All except 100x80 : 6m 100x80 : 4m	Suction <= 125 : 6m 125x100 : 4m
Synchronous speed		3600min ⁻¹ 1800min ⁻¹	
Installation		Indoor	Outdoor
Construction	Shaft seal	Gland Packing	Mechanical Seal
	Bearing	Sealed Ball	
Material	Casing	Cast Iron	
	Impeller	All except : Bronze 150 x 125 J, K, L & 200 x 150 J : Ductile Cast Iron	
	Shaft	403 Stainless Steel	
Flange	Suction	JIS 10 KRF	
	Discharge	JIS 10 KRF	
Accessories			
Optional	Common base, Anchor bolts, Shaft coupling, Coupling guard.		

■ DIMENSION

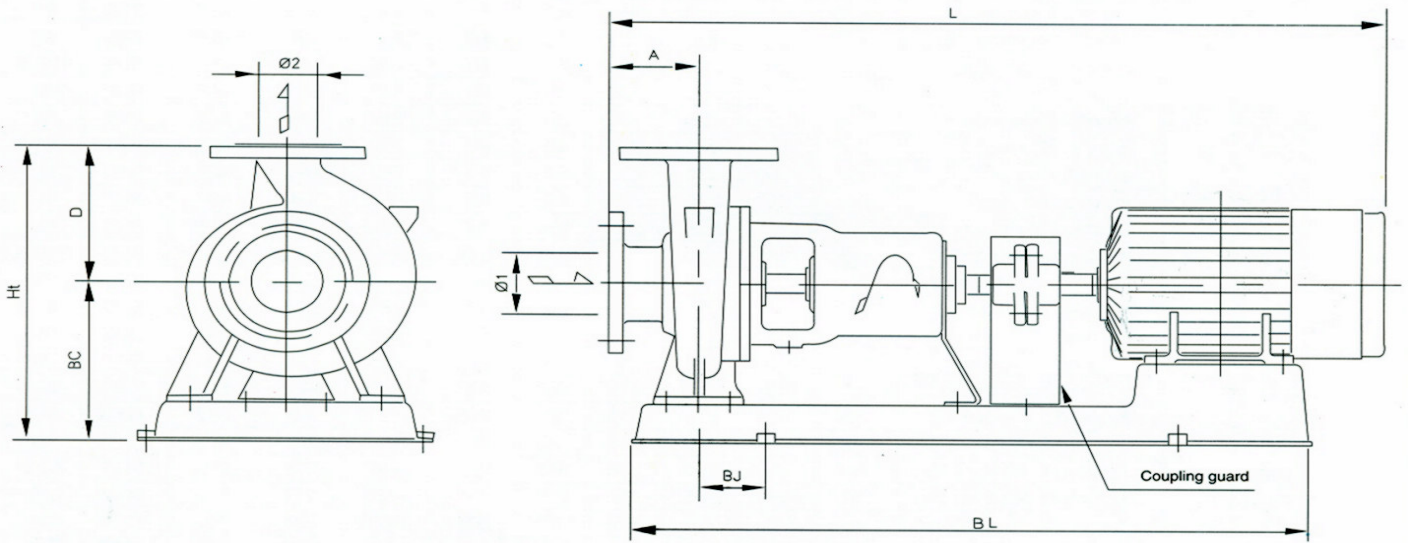

2 POLE - 3600rpm

Unit: mm

Size		Model	Output kW	Pump				Common Base			Total		
Ø1	Ø2			A	BC	D	w t kg	BJ	BL	w t kg	Ht	L	w t kg
50	40	50X40 FS2HA63.7	3.7	80	215	180	37	55	740	29	395	825	108
		50X40 FS2HA65.5	5.5	80	230	180	37	55	820	30	410	889	132
		50X40 FS2HA67.5	7.5	80	230	180	37	55	820	30	410	889	132
65	50	65X50 FS2HA65.5	5.5	100	230	180	42	55	820	30	410	909	137
		65X50 FS2HA67.5	7.5	100	230	180	42	55	820	30	410	909	137
		65X50 FS2HA611	11	100	250	180	42	98	920	47	430	1067	209
		65X50 FS2HA615	15	100	250	180	42	98	920	47	430	1067	209
		65X50 FS2JA618	18	100	270	225	49	98	920	47	495	1111	254
80	65	80X65 FS2GA611	11	100	250	180	39	98	920	47	430	1067	206
		80X65 FS2GA615	15	100	250	180	39	98	920	47	430	1067	206
		80X65 FS2HA618	18	100	270	200	48	98	920	47	470	1111	253
		80X65 FS2JA622	22	100	270	225	60	98	920	47	495	1130	287
		80X65 FS2JA630	30	100	275	225	60	95	1040	65	500	1231	415
100	80	100X80 FS2GA618	18	100	270	200	49	98	920	47	470	1111	254
		100X80 FS2GA622	22	100	270	200	49	98	920	47	470	1130	276
		100X80 FS2HA630	30	100	275	225	62	95	1040	65	500	1232	417
		100X80 FS2HA637	37	100	275	225	62	95	1040	65	500	1232	417
		100X80 FS2HA645	45	100	275	225	62	95	1040	65	500	1270	482

All specifications subject to change without prior notice.



EBARA BENGUET, INC.

Canlubang Industrial Estate

Cabuyao 4025, Laguna, Philippines

P.O.Box3461 MCPO 1274 Makati

Tel : (02)832-6230, (02) 832-8891, (02) 6800-6037, (049) 549-1806

Fax: (02) 552-7905, (049) 549-1915

Email: pumpsales@ebaraphilippines.com

Website : www.ebaraphilippines.com